

## THE FOLLOWING USER MANUAL APPLIES TO THE TSUNAMI DUST COLLECTOR DRYERS

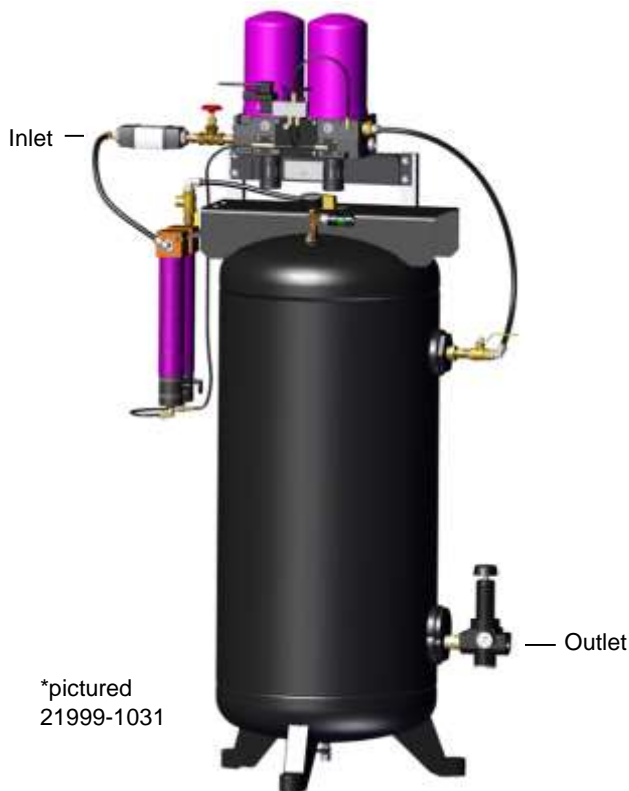

### User Manual: Tsunami Regenerative Dryers



#### WARNING

Your safety is very important. Read all instructions before beginning any service or installation on your Tsunami Regenerative Dryer. Always wear safety eye protection when working with compressed air products. Failure to follow maintenance instructions could result in operating failure or product damage. System pressure must be released prior to any installation or service. Always install the system with the arrows indicating the direction of airflow. Use appropriate thread sealant on all connection fittings unless otherwise specified. Do not alter the filtration system from its original design as this may cause failure in its operation parameters.

#### DESCRIPTION

Congratulations on the purchase of your Tsunami Regenerative Drying System! By adhering to the specifications and maintenance schedule listed in the manual, your air system will provide years of service with minimal maintenance.

Incoming air passes through an inlet ball valve before entering the 1st stage water separator where water and particulates are removed down to 10 micron. The air then travels through the 2nd stage oil coalescing filter where oil aerosols are filtered down to .001 ppm and particulates are trapped down to .01 micron. The pretreated air enters the regenerative dryer where molecular sieve desiccant captures water vapor. Approximately every 90 seconds, the timer sends out a signal causing an internal piston to shift. The shift in the piston redirects air flow through the opposite dryer canister. The pretreated air is then stored in a 60 gallon storage tank. This Tsunami Regenerative Drying System can provide dew points down to -80°F and relative humidity down to .01% RH. The Pure-10T comes standard with Moisture Minder® Drains to assume proper disposal of all contaminants captured in the water separator and oil coalescing filter.

#### DRYER SPECIFICATIONS

Maximum Inlet Air Temperature: 150°F  
 Maximum Pressure: 175 psi  
 Maximum Flow: 40 SCFM  
 Inlet Port: 1/2" NPT  
 Outlet Port: 1" NPT

Pneumatically powered dryers consume an additional 1-2 SCFM worth of air

#### INSTALLATION & SERVICE REQUIREMENTS

**IMPORTANT: Tsunami Regenerative Dryers are configurable in multiple variations. Before beginning installation it is important to determine the direction of air flow which best meets your installation application requirements. Failure to follow mandatory maintenance schedule will void warranty.**

Dryer Installation & Configuration .....	pg. 1
Mandatory 6 Month Service .....	pg. 2
•Oil Coalescing Filter Element Replacement (P/N: 21999-0202)	
Recommended 6 Month Service .....	pg. 2
•Lubrication of piston spool and piston bore (P/N: 21999-0202)	
Recommended Annual Service .....	pg. 2
•Replacement of piston spool and piston bore (P/N: 21999-0707)	
Recommended 3 Year Service .....	pg. 3
•Replacement of dryer canisters (P/N: 21999-0349)	
Troubleshooting Guide .....	pg. 3

#### INSTALLATION INSTRUCTIONS

For 110v dryers, plug unit into wall.  
 For 220v dryers, install a 220/230/240 single phase plug on flying leads and plug into appropriate outlet or hardwire into gauge box. Make sure all local electrical codes are followed and that work is performed by a qualified representative.

Figure 1

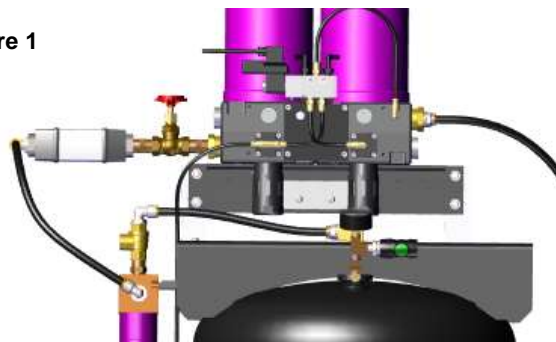

**Once all air connections are complete, verify generator regulator is set to 55 psi (Pneumatically-powered models only).**

Pure-10T dryers come standard with a built-in bypass circuit to allow for maintenance or service without the need for shut down of the facility's air system. Verify air dryer pressure is relieved prior to performing service of any kind.

Using the dryer: Figure 1 reflects drying system in standard operating mode. To bypass the dryer, rotate both inlet and outlet ball valves 90° clockwise. Before performing service to any filters, canisters, drains etc. verify all pressure has been released by pulling the safety release valve on bottom of dryer.

**A ball valve is located on the bottom of the tank for manual draining purposes. It is recommended to leave the ball valve open any time the system is being bypassed.**

# USER MANUAL

## MAINTENANCE INSTRUCTIONS - COALESCING ELEMENT

**Mandatory every 6 months**

- Oil Coalescing Filter Element Replacement (P/N: 21999-0202)

Your safety is very important. Read all instructions before beginning any service or installation on your Tsunami Regenerative Dryer. Always wear safety eye protection when working with compressed air products. Failure to follow maintenance instructions could result in operating failure or product damage. System pressure must be released prior to any installation or service.

Figure 1



- Unplug unit from power source.
- Release all system pressure.
- Disconnect the pilot line located at the bottom of the oil coalescing filter.
- Remove filter tube from filter head by holding filter head and rotating tube counter-clockwise.
- Using a 5/16" wrench, remove baffle nut from threaded rod below element.
- Remove bottom baffle, filter element, top adaptor, and O-ring. Figure 2

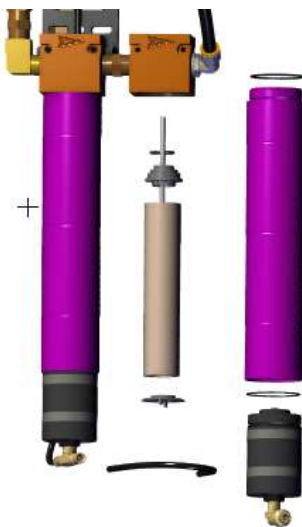

Figure 2

- Replace filter element and hardware in reverse order from previous steps. Tighten baffle nut until filter element can no longer spin freely. **DO NOT OVER TIGHTEN NUT!**
- Reinstall outer tube by rotating clockwise onto filter head.
- Reconnect pilot tubing and plug unit back into wall.
- Slowly pressurize the unit.

## MAINTENANCE INSTRUCTIONS - PISTON LUBRICATION

**Recommended every 6 months**

- Lubrication of piston spool and piston bore (21999-0202)

**Recommended annually**

- Piston Replacement Kit (21999-0707)

Your safety is very important. Read all instructions before beginning any service or installation on your Tsunami Regenerative Dryer. Always wear safety eye protection when working with compressed air products. Failure to follow maintenance instructions could result in operating failure or product damage. System pressure must be released prior to any installation or service.

Figure 3

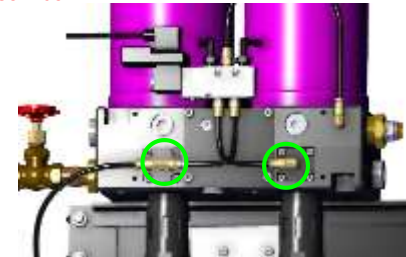

Note: Each canister contains one piston

- Unplug unit from power source.
- Release all system pressure.
- Disconnect tubing from quick-connect fitting located on piston cover. Push in on brass ring. While holding ring in, pull out tubing. Figure 3
- Using a 4mm hex key wrench, remove the four socket head cap screws holding the piston cover in place. Figure 4
- Remove piston cover for access to piston.
- Using a finger or a 1/2-13 bolt, remove the piston from the piston bore. Be sure to remove the piston spring. Figure 4
- Using dielectric grease, lubricate the piston bore. Grease thoroughly.
- Lubricate the top three O-rings located on the piston.



Figure 4

Note: It is unnecessary to grease bottom O-ring (small diameter).

- Place spring back onto piston.
- Carefully insert piston back into piston bore. Press until piston is fully seated.
- Replace piston cover for access to piston.
- Using a 4mm hex key wrench, replace the four socket head cap screws holding the piston cover in place. Tighten until snug, then add 1/4 turn. Figure 4
- Reconnect tubing to quick-connect fitting located on piston cover. Figure 3
- Slowly pressurize the unit.

## SERVICE INSTRUCTIONS - DRYER CANISTER REPLACEMENT

### Recommended 3 Year Service

•Replacement of dryer canisters (P/N: 21999-0349)

Your safety is very important. Read all instructions before beginning any service or installation on your Tsunami Regenerative Dryer. Always wear safety eye protection when working with compressed air products. Failure to follow maintenance instructions could result in operating failure or product damage. System pressure must be released prior to any installation or service.

Unplug unit from power source.

Release all system pressure.

Using a strap wrench (if necessary), unscrew each canister from the top of the dryer housing. Discard.

Remove and discard small O-ring from dryer mounting stud.

Remove and discard large gasket from canister housing.

Clean top surface of dryer housing and mounting stud.

Using the supplied grease, apply light coating to the new O-ring.

Install O-ring onto mounting stud. Figure 5

Apply a light amount of the supplied grease to the new canister gasket. Figure 5

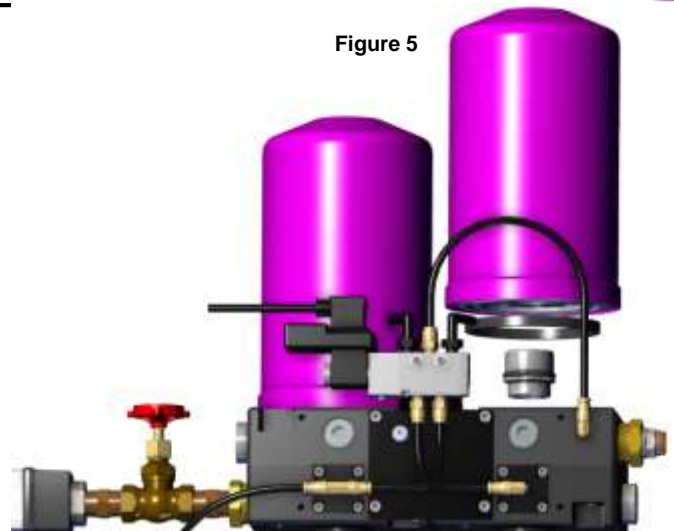
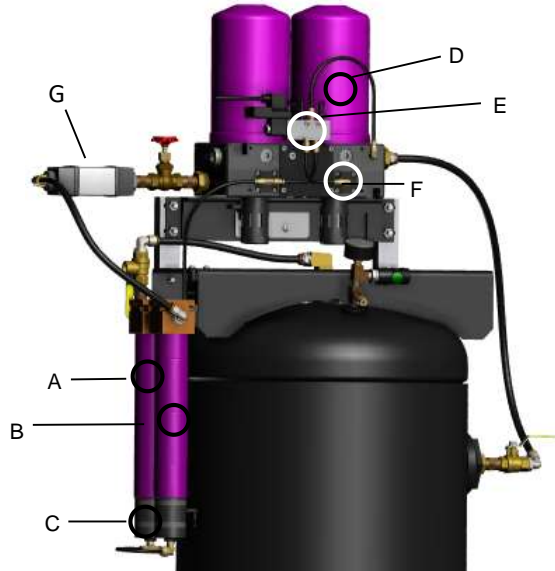

Figure 5

Thread new canister onto the mounting stud. Once gasket contacts adaptor plate, tighten canister 1/2 turn. DO NOT OVERTIGHTEN.

## TROUBLESHOOTING GUIDE - TSUNAMI REGENERATIVE DRYER



- A** Water Separator  
Service Kit PN: 21999-0227
- B** Oil Coalescing Element  
Replacement PN: 21999-0202
- C** Moisture Minder® Filter Drains  
Replacement PN: 21999-0795
- D** Dryer Desiccant Canister  
Replacement PN: 21999-0349
- E** Solenoid Timer Valve  
Replacement PN: 21999-0941
- F** Piston  
Replacement PN: 21999-0707
- G** Regulator  
Flow Meter PN: H671A-050

PROBLEM	PROBABLE CAUSE	CORRECTION
Water / Oil Carryover	A. Water Separator not properly draining B. Moisture Minder® Drain not working C. Coalescing filter element cracked or saturated D. Desiccant tower saturated or oil carryover has gotten on the media E. Over flowing dryer F. Dryer not sized properly	a. Remove and verify automatic drains are functioning. b. Check to see if Moisture Minder® is dispersing water. If not, replace. c. Replace coalescing filter element. See Maintenance Instructions Page 2. d. Replace desiccant canister. See Service Instructions Page 3. e. Reduce the SCFM being used downstream of dryer. Contact Distributor. f. Contact your distributor for more info.
Excess Air Purging Out Muffler	A. Piston stuck	a. Grease or replace piston. See Maintenance Instructions Page 2.
Dryer Not Cycling	A. Power cord damaged B. Solenoid Timer Valve not properly working	a. Replace power cord. Contact your distributor for more information. b. Replace solenoid timer valve.